

VA 520 - Inline flow meter

NEW: Modbus-RTU output
4...20 mA output for present flow

Pulse output for total flow (counter reading), galvanically isolated or M-Bus (optionally)

Measuring unit can be unscrewed:
Removal of the entire measuring section not necessary, no by-pass necessary

Display head rotatable by 180° e.g. in case of reverse flow direction

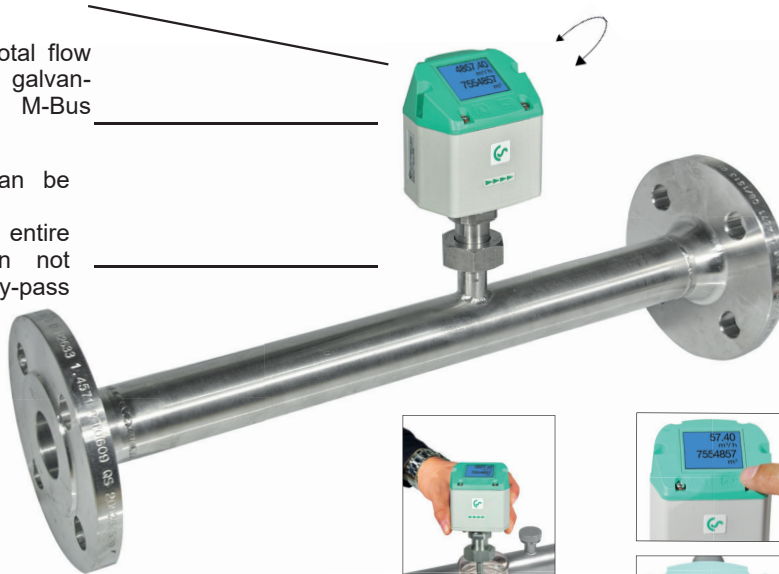

Display shows 2 values at the same time:

- Present flow in m³/h, l/min,...
- Total consumption (counter reading) in m³, l
- Temperature measurement

Readout values in the display can be rotated by 180°, e.g. for overhead installation

Easy installation into the existing pipeline due to integrated measuring section and weld neck flange (according to EN 1092-1 PN 40)

High measuring accuracy due to defined measuring section (inlet and outlet section)



The sensor can be removed and cleaned



With a key stroke:

- Reset counter reading
- Select units
- Zero-point adjustment, leak flow volume suppression



Option:

Bi-directional measurement. Blue or green arrows in the display indicate the direction of flow.

A meter reading is available for each flow direction.



Application-technological features of the flow meters VA 520:

- Digital interfaces such as Modbus-RTU, Ethernet (PoE) and M-Bus enable connection to higher-level systems such as energy management systems, building management systems, PLC,...
- Easy and affordable installation
- Units freely selectable via keys on the display m³/h, m³/min, l/min, l/s, kg/h, kg/min, kg/s, cfm
- Compressed air counter up to 1,999,999,999 m³ can be reset to "zero" via keypad
- Analog output 4...20 mA, pulse output (electrically isolated)
- High measuring accuracy even in the lower measuring range (ideal for leakage measurement)
- Negligibly small loss of pressure
- Calorimetric measuring principle, no additional pressure and temperature measurement necessary, no mechanically moved parts
- Comprehensive diagnostic functions can be read out on the display or remote access via Modbus-RTU such as exceeding max./min values °C, calibration cycle, error codes, serial number. All parameters can be read out and changed via Modbus

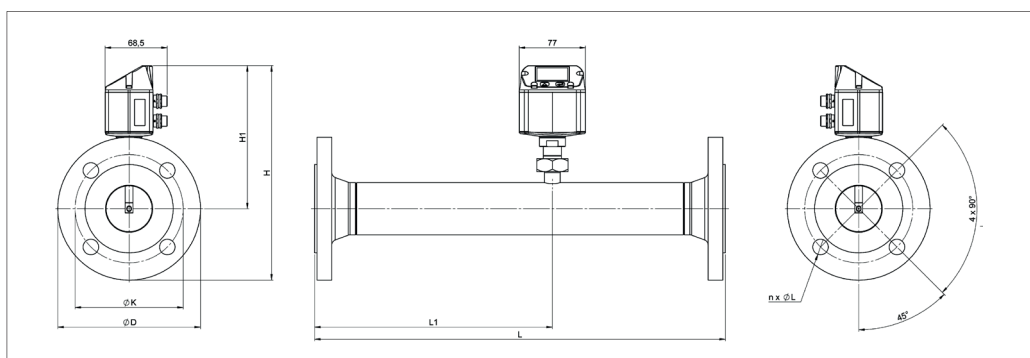

Flow measuring ranges VA 520 (Max version 185 m/s) for compressed air (ISO 1217: 1000 mbar, 20°C) Measuring ranges for other types of gas see pages 110 to 113									Flange DIN EN 1092-1		
Measuring section	Outer pipe mm	Inner pipe mm	Measuring range full scales		L mm	L1 mm	H mm	H1 mm	ØD mm	ØK mm	n x ØL
			m³/h	(cfm)							
DN 15	21.3	16.1	90	50	300	210	213.2	165.7	95	65	4 x 14
DN 20	26.9	21.7	175	100	475	275	218.2	165.7	105	75	4 x 14
DN 25	33.7	27.3	290	170	475	275	223.2	165.7	115	85	4 x 14
DN 32	42.4	36.0	530	310	475	275	235.7	165.7	140	100	4 x 18
DN 40	48.3	41.9	730	430	475*	275	240.7	165.7	150	110	4 x 18
DN 50	60.3	53.1	1195	700	475*	275	248.2	165.7	165	125	4 x 18
DN 65	76.1	68.9	2050	1205	475*	275	268.2	175.7	185	145	8 x 18
DN 80	88.9	80.9	2840	1670	475*	275	275.7	175.7	200	160	8 x 18

*Attention: Shortened inlet section. Please observe the recommended minimum inlet section (length = 15 x inner diameter) on site.

DESCRIPTION	ORDER NO.	TECHNICAL DATA VA 520
VA 520 flow meter with integrated DN 15 measuring section with flange	0695 2521	Parameters: m³/h, l/min (1000 mbar, 20 °C) in case of compressed air or Nm³/h, NI/min (1013 mbar, 0 °C) in case of gases Units adjustable via keys at display: m³/h, m³/min, l/min, l/s, ft/min, cfm, m/s, kg/h, kg/min, g/s, lb/min, lb/h Sensor: Thermal mass flow sensor Measured medium: Air, gases Gas types are adjustable over CS service software or CS data logger: Air, nitrogen, argon, CO2, oxygen Measuring range: See table above Accuracy: ± 1.5% of m.v. ± 0.3% of f.s. on request: ± 1% of m.v. ± 0.3% of f.s. Operating temperature: -30...80 °C Operating pressure: -1 to 16 bar optionally up to PN 40 Digital output: RS 485 interface, (Modbus-RTU), optional: Ethernet interface PoE), M-Bus Analogue output: 4...20 mA for m³/h or l/min Pulse output: 1 pulse per m³ or per litre electrically isolated. Pulse weight can be set on the display. Alternatively, the pulse output can be used as an alarm relay Supply: 18...36 VDC, 5 W Burden: < 500 Ω Housing: Polycarbonate (IP 65) Measuring section: Stainless steel, 1.4301 or 1.4571 Process connection: Flange (in acc. with DIN EN 1092-1 or ANSI 150 lbs or ANSI 300 lbs) Mounting position: any
VA 520 flow meter with integrated DN 20 measuring section with flange	0695 2522	
VA 520 flow meter with integrated DN 25 measuring section with flange	0695 2523	
VA 520 flow meter with integrated DN 32 measuring section with flange	0695 2526	
VA 520 flow meter with integrated DN 40 measuring section with flange	0695 2524	
VA 520 flow meter with integrated DN 50 measuring section with flange	0695 2525	
VA 520 flow meter with integrated DN 65 measuring section with flange	0695 2527	
VA 520 flow meter with integrated DN 80 measuring section with flange	0695 2528	
Bi-directional measurement - includes 2 x 4...20 mA analogue outputs and 2x pulse outputs. These do not apply to Ethernet (PoE) and M-Bus	Z695 6000	
High-pressure version PN 40	Z695 0411	
ANSI flange 150 lbs (instead of DIN flanges)	Z695 5013	
ANSI flange 300 lbs (instead of DIN flanges)	Z695 5014	
Measuring ranges: Low-Speed (50 m/s) Standard (92.7 m/s) High-Speed (224 m/s)	Z695 0520 Z695 0521 Z695 0522	
Options: DVGW approval for natural gas (maximum pressure 16 bar) Special measuring range for VA 520 on customer request 1% accuracy of m.v. ± 0.3 % of f.s. Ethernet interface for VA 500/520 and FA 500 Ethernet interface PoE for VA 500/520 and FA 500 M-Bus board for VA 500/520 and FA 500	Z695 5016 Z695 4006 Z695 5005 Z695 5006 Z695 5007 Z695 5004	
ISO calibration certificate (5 calibration points) for VA sensors Gas type:___ (specify gas type when placing order) Gas mixture:___ (specify gas mixture when placing order) Real gas adjustment Special cleaning oil and grease free (e.g. for oxygen applications) LABS and silicone-free version including cleaning oil and grease-free Additional calibration curve stored in the sensor (can be selected via display) Certificate of origin	3200 0001 Z695 5009 Z695 5010 3200 0015 0699 4005 0699 4007 Z695 5011 Z695 5012	

For further accessories refer to pages 102 to 106

VA 520 - Inline flow meter

NEW: Modbus-RTU output

Display head rotatable by 180 ° e.g. in case of reverse flow direction

4...20 mA output for present flow

Pulse output for total flow (counter reading), galvanically isolated or M-Bus (optionally)

Measuring unit can be unscrewed: Removal of the entire measuring section not necessary, no by-pass necessary

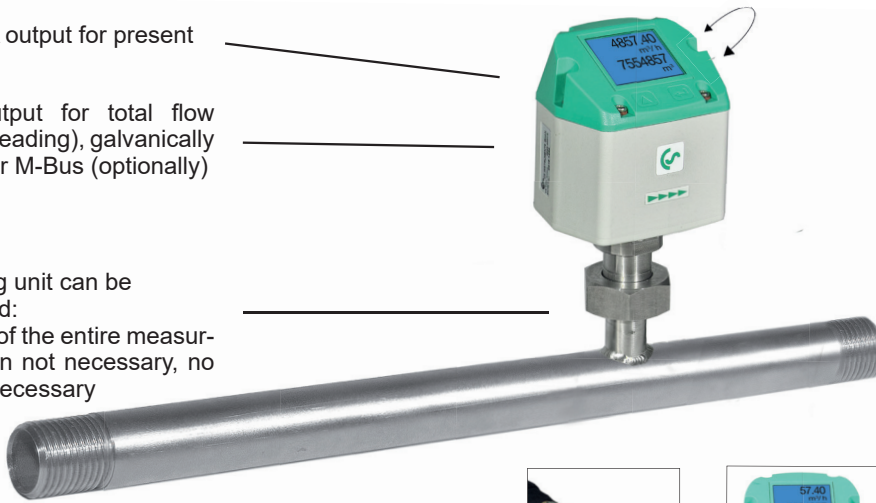

Display shows 2 values at the same time:

- Present flow in m³/h, l/min,...
- Total consumption (counter reading) in m³, l
- Temperature measurement

Readout values in the display can be rotated by 180°, e.g. for overhead installation

Easy installation into the existing pipe due to integrated measuring section (1/4" to 2")

High measuring accuracy due to defined measuring section (inlet and outlet section)



The sensor can be removed and cleaned



With a key stroke:

- Reset counter reading
- Select units
- Zero-point adjustment, leak flow volume suppression

Option:

Bi-directional measurement. Blue or green arrows in the display indicate the direction of flow. A meter reading is available for each flow direction.

Application-technological features of the flow meters VA 520:

- Digital interfaces such as Modbus-RTU, Ethernet (PoE) and M-Bus enable connection to higher-level systems such as energy management systems, building management systems, PLC,...
- Easy and affordable installation
- Units freely selectable via keys on the display m³/h, m³/min, l/min, l/s, kg/h, kg/min, kg/s, cfm
- Compressed air counter up to 1,999,999,999 m³ can be reset to "zero" via keypad
- Analog output 4...20 mA, pulse output (electrically isolated)
- High measuring accuracy even in the lower measuring range (ideal for leakage measurement)
- Negligibly small loss of pressure
- Calorimetric measuring principle, no additional pressure and temperature measurement necessary, no mechanically moved parts
- Comprehensive diagnostic functions can be read out on the display or remote access via Modbus-RTU such as exceeding max./min values °C, calibration cycle, error codes, serial number. All parameters can be read out and changed via Modbus

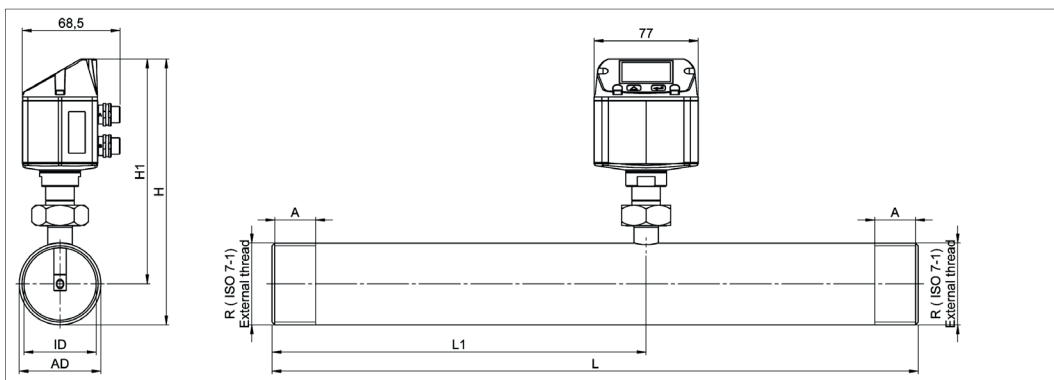

Flow measuring ranges VA 520 (max version 185 m/s) for compressed air (ISO 1217: 1000 mbar, 20 °C)									
Measuring range for other gases see pages 110 to 113									
Connection thread	Outer pipe mm	Inner pipe mm	Measuring range full scales		L mm	L1 mm	H mm	H1 mm	A mm
			m ³ /h	cfm					
R 1/4"	13.7	8.9	105 l/min	3.6	194	137	174.7	165.7	15
R 3/8"	17.2	12.5	50	29.4	300	200	175	165.7	15
R 1/2"	21.3	16.1	90	50	300	210	176.4	165.7	20
R 3/4"	26.9	21.7	175	100	475	275	179.2	165.7	20
R 1"	33.7	27.3	290	170	475	275	182.6	165.7	25
R 1 1/4"	42.4	36.0	530	310	475	275	186.9	165.7	25
R 1 1/2"	48.3	41.9	730	430	475*	275	186.9	165.7	25
R 2"	60.3	53.1	1195	700	475*	275	195.9	165.7	30

*Attention: Shortened inlet section. Please observe the recommended minimum inlet section (length = 15 x inner diameter) on site!

DESCRIPTION	ORDER NO.	ORDER NO.	TECHNICAL DATA VA 520
	Stainless steel 1.4571	Stainless steel 1.4301	
VA 520 flow meter with 1/4" measuring section	0695 1520	0695 0520	<p>Parameters: m³/h, l/min (1000 mbar, 20 °C) in case of compressed air or Nm³/h, NI/min (1013 mbar, 0 °C) in case of gases</p> <p>Units adjustable via keys at display: m³/h, m³/min, l/min, l/s, ft³/min, cfm, m/s, kg/h, kg/min, g/s, lb/min, lb/h</p> <p>Sensor: Thermal mass flow sensor</p> <p>Measured medium: Air, gases</p> <p>Gas types are adjustable over CS service software or CS data logger: Air, nitrogen, argon, CO₂, oxygen</p> <p>Measuring range: See table above</p> <p>Accuracy: (o. M. V. = of measured value) (o. F. S. = of full scale) ± 1.5% of m.v. ± 0.3 % of f.s. on request: ± 1% of m.v. ± 0.3% of f.s.</p> <p>Operating temperature: -30...80 °C</p> <p>Operating pressure: -1 to 16 bar optionally up to PN 40</p> <p>Digital output: RS 485 interface, (Modbus-RTU), optional: Ethernet interface PoE), M-Bus</p> <p>Analogue output: 4...20 mA for m³/h or l/min</p> <p>Pulse output: 1 pulse per m³ or per litre electrically isolated. Pulse weight can be set on the display. Alternatively, the pulse output can be used as an alarm relay</p> <p>Supply: 18...36 VDC, 5 W</p> <p>Burden: < 500 Ω</p> <p>Housing: Polycarbonate (IP 65)</p> <p>Measuring section: Stainless steel, 1.4301 or 1.4571</p> <p>Connection thread of measuring sections R 1/4" to R 2" (BSP British Standard Piping) or 1/2" to 2" NPT thread</p> <p>Mounting position: any</p>
VA 520 flow meter with 3/8" measuring section	0695 1527	0695 0527	
VA 520 flow meter with 1/2" measuring section	0695 1521	0695 0521	
VA 520 flow meter with 3/4" measuring section	0695 1522	0695 0522	
VA 520 flow meter with 1" measuring section	0695 1523	0695 0523	
VA 520 flow meter with 1 1/4" measuring section	0695 1526	0695 0526	
VA 520 flow meter with 1 1/2" measuring section	0695 1524	0695 0524	
VA 520 flow meter with 2" measuring section	0695 1525	0695 0525	
Bi-directional measurement - includes 2x4...20 mA analogue outputs and 2x pulse outputs. These do not apply to Ethernet (PoE) and M-Bus	Z695 6000	Z695 6000	
High-pressure version PN 40	Z695 0411	Z695 0411	
NPT thread (instead of R thread) - can only be ordered for stainless steel 1.4571	Z695 5015		
Measuring ranges:			
Low-Speed (50 m/s)		Z695 0520	
Standard (92.7 m/s)		Z695 0521	
High-Speed (224 m/s)		Z695 0522	
Options:			
DVGW approval for natural gas (max. pressure 16 bar)		Z695 5016	
Special measuring range for VA 520 on customer request		Z695 4006	
1% accuracy of m.v. ± 0.3 % of f.s.		Z695 5005	
Ethernet interface for VA 500/520 and FA 500		Z695 5006	
Ethernet interface PoE for VA 500/520 and FA 500		Z695 5007	
M-Bus board for VA 500/520 and FA 500		Z695 5004	
ISO calibration certificate (5 calibration points) for VA sensors		3200 0001	
Gas type:____ (specify gas type when placing order)		Z695 5009	
Gas mixture:____ (specify gas mixture when placing order)		Z695 5010	
Real gas adjustment		3200 0015	
Special cleaning oil and grease free (e.g. for oxygen applications)		0699 4005	
LABS and silicone-free version including cleaning oil and grease-free		0699 4007	
Additional calibration curve stored in the sensor (can be selected via display)		Z695 5011	
Certificate of origin		Z695 5012	

For further accessories refer to pages 102 to 106