



Remote Monitoring for Business

Wireless Dry Contact Sensors

General Description

[ALTA Wireless Dry Contact Sensors](#) can be used to detect contact between two wired contact points, an external mechanical switch or a contact plate.

- 1 ft (12 inch) lead wires
- Can integrate with switches

Principle of Operation

The ALTA Wireless Dry Contact Sensor detects when there is contact between the two wired end points. It can easily be integrated into existing switches or contact plates. When the sensor detects contact between the two end points, it will immediately turn on the RF radio and transmit the data to the wireless gateway and iMonnit Online Sensor Monitoring and Notification System, allowing the user to immediately receive an SMS text or email alert. The sensor can be configured to detect both closed and open loops alerting if contact is made or broken and alert on state changes.

Example Applications

- Barn door monitoring
- Freezer/cooler door monitoring
- Forklift seat switches
- Button or switch integration
- Production line tracking

Features of Monnit ALTA Sensors

- Wireless range of 1,200+ feet through 12+ walls¹
- Frequency-Hopping Spread Spectrum (FHSS)
- Best-in-class interference immunity
- Best-in-class power management for longer battery life²
- Encrypt-RF[®] Security (Diffie-Hellman Key Exchange + AES-128 CBC for sensor data messages)
- Data logs 2000 to 4000 readings if the gateway connection is lost (non-volatile flash, persists through the power cycle):
 - 10-minute heartbeats = ~ 22 days
 - 2-hour heartbeats = ~ 266 days
- Over-the-air updates (future-proof)
- Free iMonnit Basic Online Wireless Sensor Monitoring and Notification System to configure sensors, view data, and set alerts to be sent via SMS text and email



1 Actual range may vary depending on the environment.

2 Battery life is determined by the sensor reporting frequency and other variables. Other power options are also available.

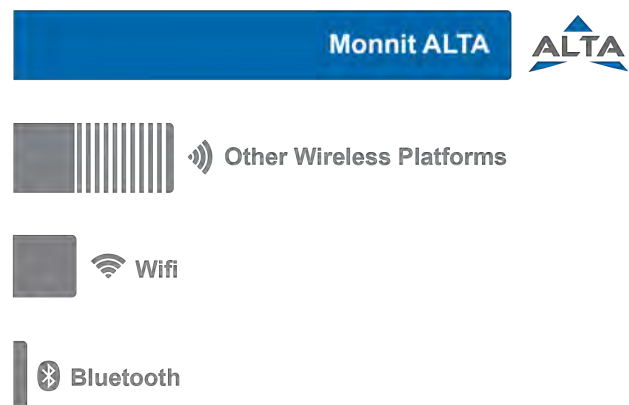
Wireless Range Comparison

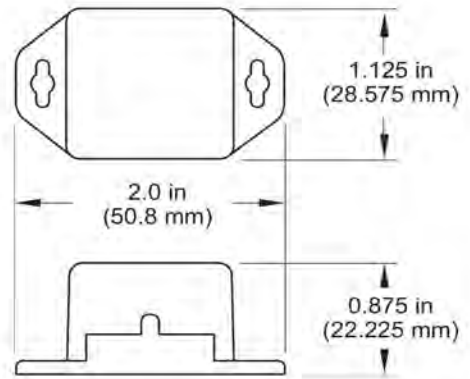





ALTA Commercial Coin Cell Wireless Dry Contact Sensor Technical Specifications	
Supply voltage	2.0–3.8 VDC ¹
Current consumption	0.2 μ A (sleep mode), 0.7 μ A (RTC sleep), 570 μ A (MCU idle), 2.5 mA (MCU active), 5.5 mA (radio RX mode), 22.6 mA (radio TX mode)
Operating temperature range (board circuitry and coin cell)	-7°C to +60°C (20°F to +140°F)
Optimal battery temperature range (coin cell)	+10°C to +50°C (+50°F to +122°F)
Lead wire length	30.4cm (12 inches)
Detection wires	High impedance
Data logging	Data logs 2000 to 4000 readings if the gateway connection is lost (non-volatile flash, persists through the power cycle): - 10-minute heartbeats = ~ 22 days - 2-hour heartbeats = ~ 266 days
Wireless range	1,200+ ft non-line-of-sight
Security	Encrypt-RF® (256-bit key exchange and AES-128 CTR)
Weight	0.7 ounces
Certifications	  Industry Canada 900 MHz product; FCC ID: ZTL-G2SC1 and IC: 9794A-G2SC1. 868 and 433 MHz product tested and found to comply with: EN 300 220-2 V3.1.1 (2017-02), EN 300 220-2 V3.1.1 (2017-02) and EN 60950

¹ Hardware cannot withstand negative voltage. Please take care when connecting a power device.

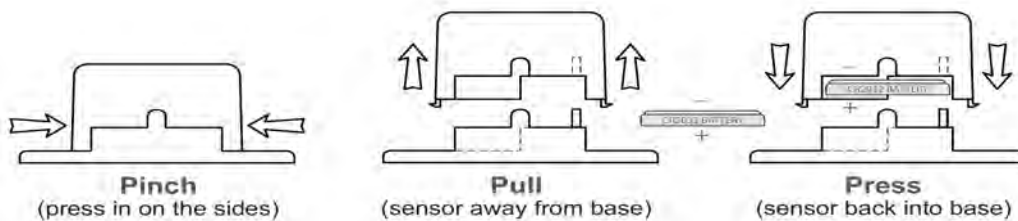
PinchPower™ Enclosures

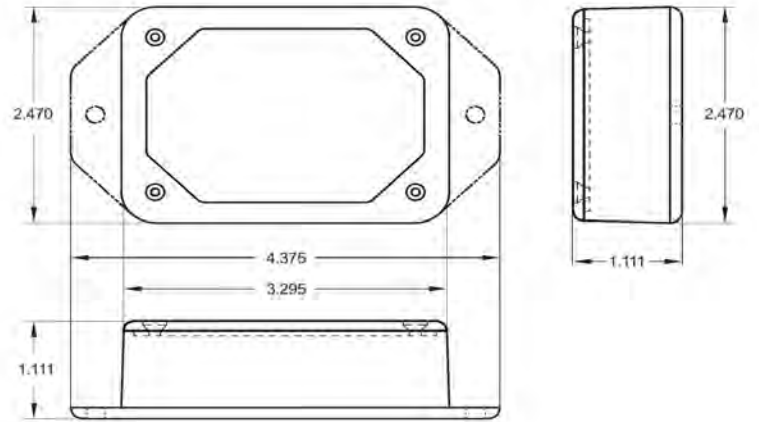



ALTA Commercial AA Wireless Dry Contact Sensor Technical Specifications	
Supply voltage	2.0–3.8 VDC (5.0–12 VDC using power supply) ¹
Current consumption	0.2 μ A (sleep mode), 0.7 μ A (RTC sleep), 570 μ A (MCU idle), 2.5 mA (MCU active), 5.5 mA (radio RX mode), 22.6 mA (radio TX mode)
Operating temperature range (board circuitry and batteries)	-18°C to 55°C (0°F to 130°F) using alkaline -40°C to 85°C (-40°F to 185°F) using lithium
Optimal battery temperature range (AA)	+10°C to +50°C (+50°F to +122°F)
Lead wire length	30.4cm (12 inches)
Detection wires	High impedance
Data logging	Data logs 2000 to 4000 readings if the gateway connection is lost (non-volatile flash, persists through the power cycle): - 10-minute heartbeats = ~ 22 days - 2-hour heartbeats = ~ 266 days
Wireless range	1,200+ ft non-line-of-sight
Security	Encrypt-RF® (256-bit key exchange and AES-128 CTR)
Weight	3.7 ounces
Certifications	  Industry Canada 900 MHz product; FCC ID: ZTL-G2SC1 and IC: 9794A-G2SC1. 868 and 433 MHz product tested and found to comply with: EN 300 220-2 V3.1.1 (2017-02), EN 300 220-2 V3.1.1 (2017-02) and EN 60950

¹ Hardware cannot withstand negative voltage. Please take care when connecting a power device.



Power Options

The standard version of this sensor is powered by two replaceable 1.5 V AA sized batteries (included with purchase).

This sensor is also available with a line power option. The line powered version of this sensor has a barrel power connector allowing it to be powered by a standard 5.0-12V power supply. The line powered version also uses two standard 1.5 V AA batteries as backup for uninterrupted operation in the event of line power outage.

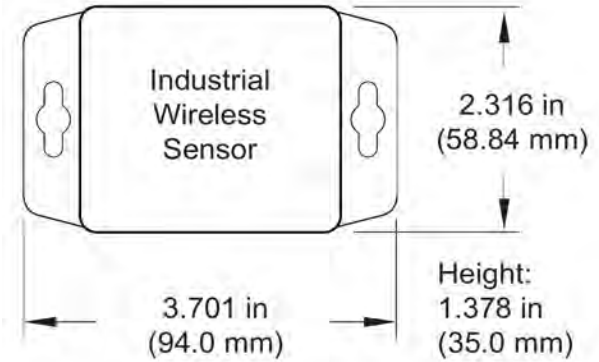
Power options must be selected at time of purchase, as the internal hardware of the sensor must be changed to support the selected power requirements.





ALTA Industrial Wireless Dry Contact Sensor Technical Specifications		
Supply voltage	2.0–3.8 VDC	
Current consumption	0.2 μ A (sleep mode), 0.7 μ A (RTC sleep), 570 μ A (MCU idle), 2.5 mA (MCU active), 5.5 mA (radio RX mode), 22.6 mA (radio TX mode)	
Operating temperature range (board circuitry and battery)	-40°C to +85°C (-40°F to +185°F) ¹	
Included battery	Max temperature range	-40° to +85°C (-40° to +185°F)
	Capacity	1800 mAh
Optional solar feature	Solar panel	5VDC/30mA (53mm x 30mm)
	Charging temperature range	0° to 45°C (32° to 113°F)
	Max temperature range	-20° to 60°C (-4° to 140°F)
	Included rechargeable battery	600 mAh/>2000 charge cycles (80% of initial capacity)
	Charging efficiency	40% ²
	Luminous sustainability	Minimum of 250 LUX ³
Solar efficiency	Optimized for high and low-light operation ²	
Lead wire length	30.4cm (12 inches)	
Detection wires	High impedance	
Data logging	Data logs 2000 to 4000 readings if the gateway connection is lost (non-volatile flash, persists through the power cycle): - 10-minute heartbeats = ~ 22 days - 2-hour heartbeats = ~ 266 days	
Wireless range	1,200+ ft non-line-of-sight	
Security	Encrypt-RF® (256-bit key exchange and AES-128 CTR)	
Weight	4.7 ounces	
Enclosure rating	NEMA 1, 2, 4, 4x, 12 and 13 rated, sealed and weather proof	
UL rating	UL Listed to UL508-4x specifications (File E194432)	
Certifications	  900 MHz product; FCC ID: ZTL-G2SC1 and IC: 9794A-G2SC1. 868 and 433 MHz product tested and found to comply with: EN 300 220-2 V3.1.1 (2017-02), EN 300 220-2 V3.1.1 (2017-02) and EN 60950	

¹ Light present 25% of day yields 125% of operating power to support 10-minute heartbeats.

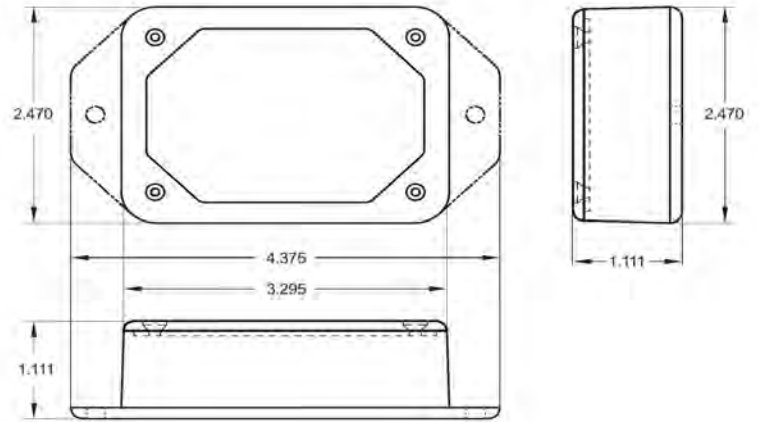
² Solar feature's energy harvesting circuitry works indoors with low light.



ALTA-ISX IECEx Wireless Dry Contact Sensor | Technical Specifications

Supply voltage	2.0–3.8 VDC
Current consumption	0.2 μ A (sleep mode), 0.7 μ A (RTC sleep), 570 μ A (MCU idle), 2.5 mA (MCU active), 5.5 mA (radio RX mode), 22.6 mA (radio TX mode)
Operating temperature range (board circuitry and batteries)	-40°C to 40°C (-40°F to 104°F)
Optimal battery temperature range (AA)	+10°C to +50°C (+50°F to +122°F)
Lead wire length	30.4cm (12 inches)
Detection wires	High impedance
Data logging	Data logs 2000 to 4000 readings if the gateway connection is lost (non-volatile flash, persists through the power cycle): - 10-minute heartbeats = ~ 22 days - 2-hour heartbeats = ~ 266 days
Wireless range	1,200+ ft non-line-of-sight
Security	Encrypt-RF® (256-bit key exchange and AES-128 CTR)
Weight	4.8 ounces (136 g)
Certifications	   900 MHz product; FCC ID: ZTL-G2SC1 and IC: 9794A-G2SC1. 868 and 433 MHz product tested and found to comply with: EN 300 220-2 V3.1.1 (2017-02), EN 300 220-2 V3.1.1 (2017-02) and EN 60950 IECEx - Ex ib IIA T3 Gb - Cert # 21.0028X

Power Options

WARNING: The sensor is supplied with a single **AA RAMWAY ER14505M battery** with a capacity of approximately 2,200 mAh. A single AA RAMWAY ER14505M lithium / thionyl chloride battery **MUST** be used and **ONLY** the RAMWAY ER14505 battery.

Commercial Grade Sensors

Monnit commercial grade sensors are designed for applications in ordinary environments (normal room temperature, humidity and atmospheric pressure). Do not use these sensors under the following conditions as these factors can deteriorate the product characteristics and cause failures and burnout.

- Corrosive gas or deoxidizing gas: chlorine gas, hydrogen sulfide gas, ammonia gas, sulfuric acid gas, nitric oxides gas, etc.
- Volatile or flammable gas
- Dusty conditions
- Low-pressure or high-pressure environments
- Wet or excessively humid locations
- Places with salt water, oils chemical liquids or organic solvents
- Where there are excessively strong vibrations
- Other places where similar hazardous conditions exist

Use these products within the specified temperature range. Higher temperature may cause deterioration of the characteristics or the material quality.

Industrial Grade Sensors | Type 1, 2, 4, 4X, 12 and 13 NEMA Rated Enclosure

Monnit's Industrial sensors are enclosed in reliable, weatherproof NEMA-rated enclosures. Our NEMA-rated enclosures are constructed for both indoor or outdoor use and protect the sensor circuitry against the ingress of solid foreign objects like dust as well as the damaging effects of water (rain, sleet, snow, splashing water, and hose-directed water).

- Safe from falling dirt
- Protects against wind-blown dust
- Protects against rain, sleet, snow, splashing water, and hose-directed water
- Increased level of corrosion resistance
- Will remain undamaged by ice formation on the enclosure