



Installation Instructions

CSV-A8 Split-Core Adjustable Current Switch



- This product is not intended for life or safety applications. This product is not intended for installation in hazardous or classified locations.
- Potential electrocution hazard exists. Installing sensors in an energized motor control center or on any energized conductor can be hazardous.
- Read instructions thoroughly prior to installation.

Severe injury or death can result from electrical shock during contact with high voltage conductors or related equipment. Disconnect and lock-out all power sources during installation and service. Applications shown are suggested means of installing sensors, but it is the responsibility of the installer to ensure that the installation is in compliance with all national and local codes. Installation should be attempted only by individuals who are familiar with codes, standards, and proper safety procedures for high-voltage installations.

INSTALLATION

1. Ensure power conductor to be monitored is disconnected and locked out from the power source!
2. Install the removable mounting bracket to the back of the electrical enclosure.
3. Snap the split core around the conductor being monitored and close until the core snaps shut.
4. Connect current switch output to DDC controller or switched load.

NOTE:

- **Contacts are solid state and work just like dry contacts. When the switch is closed, 1 Ohm is present. When the switch is open, more than 1 Meg Ohm is present.**

5. Calibrate the sensor (see calibration section)

WIRING EXAMPLE

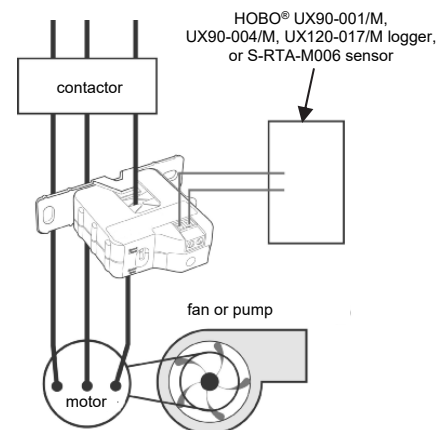

CALIBRATION AFTER INSTALLATION

Orient the current switch so the status output terminal is facing you and follow method (A) (undercurrent) or (B) (over-current), below. The monitored motor must be running normally.

A. For under current status indication: (Belt loss, coupling shear, fan & pump status)

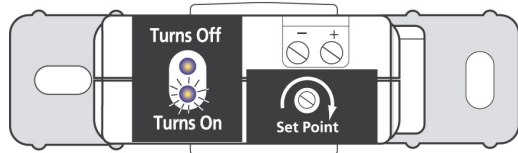

STEP 1: Turn the setpoint screw clockwise until the Status Closed LED turns off and the Status Open LED turns on.

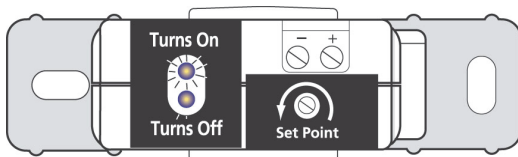

STEP 2: Slowly turn the setpoint screw counter-clockwise until the Status Closed LED turns on and the Status Open LED turns off.

STEP 3: Turn the setpoint screw 1/4 turn more counter-clockwise to create a grace margin.

STEP 4: The sensor is now calibrated to provide indication of current flows below normal full load amps.

Output Status:

Normal: Output Closed
Alarm: Output Open

B. For over current status indication: (Locked rotor, seized impeller)

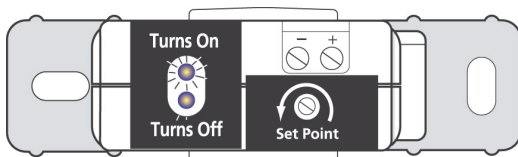

STEP 1: Turn the setpoint screw counter-clockwise until the Status Open LED turns off and the Status Closed LED turns on. (Sensor should be in this state right out of the box.)

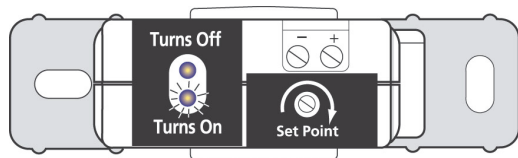

STEP 2: Slowly turn the setpoint screw clockwise until the Status Closed LED turns off and the Status Open LED turns on.



STEP 3: Turn the setpoint screw 1/4 turn more clockwise to create a grace margin.

STEP 4: The sensor is now calibrated to provide indication of current flows above normal full load amps.

Output Status:

Normal: Output Open
Alarm: Output Closed

SPECIFICATIONS

Amperage Range	0.5-175A Continuous
Sensor Supply Voltage.....	Induced from monitored conductor
Isolation.....	600VAC rms. (max. voltage when monitoring an uninsulated conductor)
Temperature Range	-15° to 60°C
Humidity Range.....	0-95% non-condensing
Status Output Ratings	N.O. 1.0A@30VAC/DC not polarity sensitive
Off-state Leakage.....	0 (open switch represents 1+ MEG ohms of resistance)
Listings.....	 UL508 E150462 

TROUBLESHOOTING

1. **The unit will not come on at all.**
 - A. Check to be sure that no more than 30VAC/DC or 1.0A has passed through the contact. Voltages or currents above these levels will damage the unit.
 - B. Verify that the conductor you are monitoring is carrying at least 0.5 Amps.
 - C. Verify that the setpoint is not above operating amps by turning screw counter-clockwise (up to 20 full turns) until the contacts close (status closed LED turns on).
2. **Set-point screw has no stops. Keeps turning.**
 - A. The 20 turn set-point screw has a slip clutch which prevents damage at either end. To start the calibration process over again turn the screw 20 full turns counter-clockwise. This sets the device in its original and most sensitive position. Resume calibration from the beginning.
3. **Both LEDs are lit.**
 - A. If the setpoint screw has been turned too far to the right the user will be notified that the current switch is out of calibration by seeing both LEDs lit. To correct this, turn the set-point screw 20 full turns counterclockwise and resume calibration from the beginning.