

# PyroEpsilon

## Pyrometer with 4-20 mA Output and Adjustable Emissivity Setting



Sensor shown with optional PyroTune emissivity adjuster

- Temperature ranges from -20°C to 500°C
- Two-wire 4-20 mA output
- Adjustable emissivity via continuously variable 4-20 mA input - measure a wide range of target materials
- Choice of precision optics for large or small targets
- Fast response with high stability
- Stainless steel housing, sealed to IP65
- Quick and easy installation
- Wide range of accessories
- Conforms to industrial EMC standards

The PyroEpsilon is a simple infrared temperature sensor with an adjustable emissivity setting. It is ideal if the target is partially reflective.

The emissivity setting is adjustable via a two-wire 4-20 mA input, and can be adjusted continuously using a variable 4-20 mA source.

To set the emissivity manually, the optional PyroTune emissivity adjuster is available. The sensor is also compatible with PLC outputs or indicating controllers that can provide a 4-20 mA signal.

If no 4-20 mA input is provided, the emissivity setting will revert to 0.95, making the sensor suitable for measuring non-reflective non-metal materials (or painted metals) out of the box.

### SPECIFICATIONS

General	
<b>Output</b>	Two-wire 4-20 mA
<b>Temperature Range</b>	LT = -20 to 100 °C MT = 0 to 250 °C HT = 0 to 500 °C
<b>Accuracy</b>	±1% of reading or ±1°C, whichever is greater
<b>Repeatability</b>	± 0.5% of reading or ± 0.5°C, whichever is greater
<b>Emissivity Setting</b>	Variable 0.2 to 1.0 via continuous 4-20 mA input
<b>Response Time</b>	240 ms (90% response)
<b>Spectral Range</b>	8 to 14 μm
<b>Supply Voltage (at Sensor)</b>	6 V DC to 28 V DC
<b>Max. Loop Impedance</b>	900 Ω (output loop)
<b>Input Impedance</b>	50 Ω (input loop)
<b>Max. Current Draw</b>	20 mA

### OPTICS

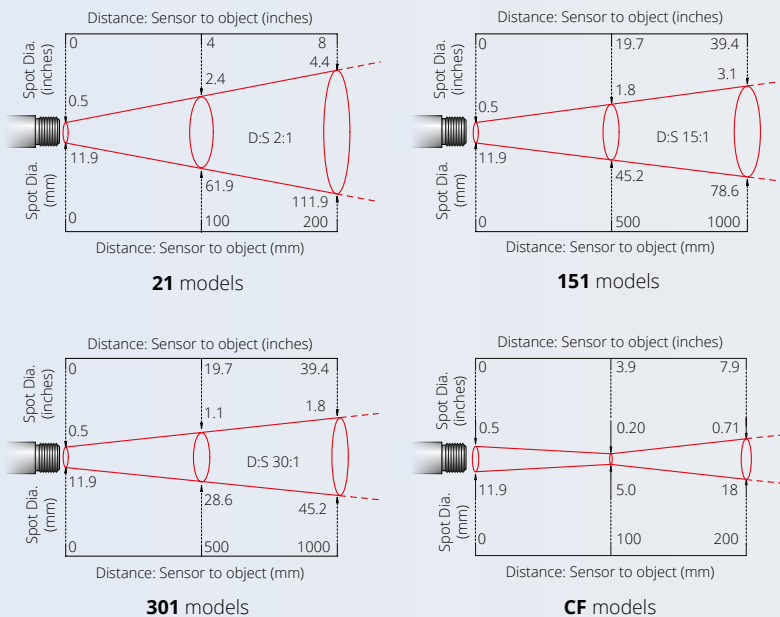

All models can measure at longer distances than shown, with a larger measured spot size.

Diagrams show the diameter of the measured target spot versus the distance from the sensing head (90% energy).

Mechanical	
<b>Construction</b>	Stainless Steel
<b>Dimensions</b>	18 mm diameter x 103 mm long
<b>Thread Mounting</b>	M16 x 1 mm pitch
<b>Cable Length</b>	1m (longer lengths available to order)
<b>Weight with Cable</b>	95 g

Environmental	
<b>Environmental (IP) Rating</b>	IP65
<b>Ambient (Operating) Temperature Range</b>	0°C to 70°C
<b>Ambient (Operating) Humidity</b>	95% max. non-condensing

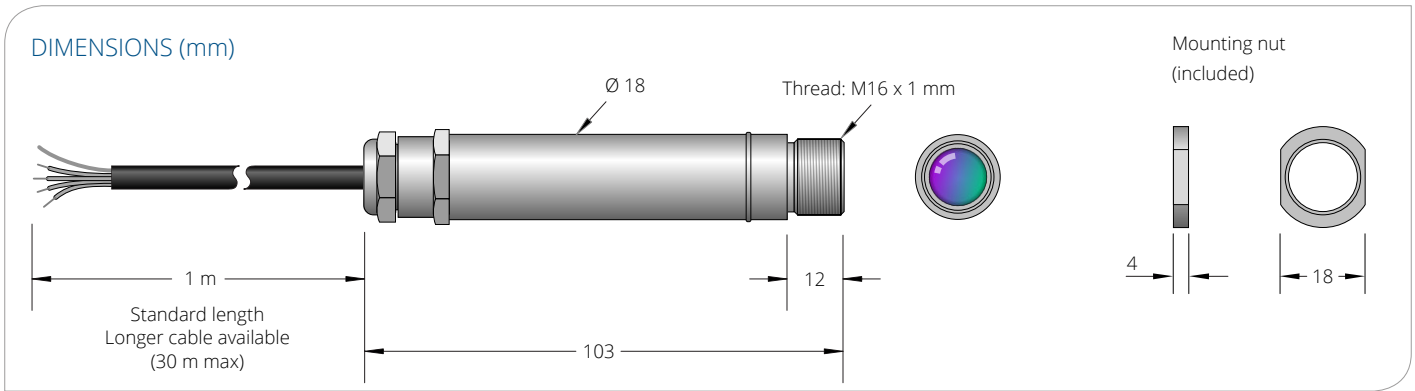

**CONNECTIONS**

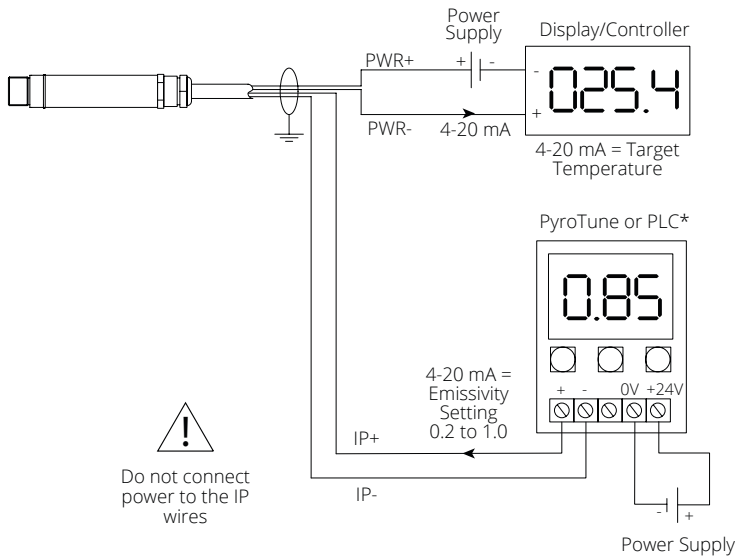

\* A choice of indicating controllers, providing emissivity adjustment for the PyroEpsilon sensor, as well as temperature display and relay outputs, is also available. Contact Calex for more information.

**PYROTUNE**



The optional PyroTune emissivity adjuster provides a continuous 4-20 mA current signal to the PyroEpsilon sensor. Simple push-button controls allow the emissivity setting to be adjusted. The built-in LCD display shows the emissivity or mA value.

PyroTune Specifications	
<b>Output</b>	4-20 mA for emissivity adjustment of PyroEpsilon sensor
<b>Supply Voltage</b>	24 V DC (13 to 28 V DC)
<b>Display Format</b>	3.5 Digit LCD
<b>Display Units</b>	Emissivity (0.2 to 1.0) or current (4-20 mA)
<b>Adjustment</b>	Push buttons (raise, lower, set)
<b>Construction</b>	Polycarbonate with gasket
<b>Dimensions</b>	65 (h) x 50 (w) x 35 (d) mm
<b>Weight</b>	72 g
<b>IP Rating</b>	IP65
<b>Ambient Temp.</b>	0°C to 70°C (operating temperature)
<b>Relative Humidity</b>	95% max (non condensing)

**MODEL NUMBERS**

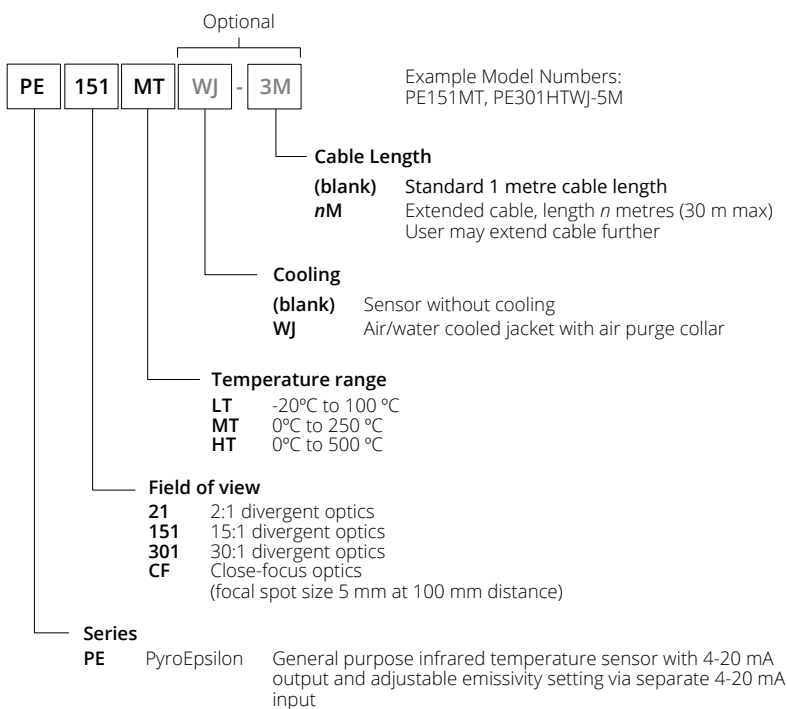

**ACCESSORIES**



Laser sighting tool **LSTS**



Dual laser sighting bracket, adjustable **DLSBAS** or fixed **DLSBFS**



Fixed mounting bracket **FBS**



Adjustable mounting bracket **ABS**



Air or water cooled jacket with air purge collar **WJ** (factory-fitted - see Model Numbers)



Air purge collar for 2:1 optics **APSW** or for all other optics (shown above) **APSN**