

# PyroCube Series

Infrared Temperature Sensors for Special Applications

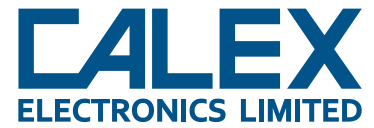

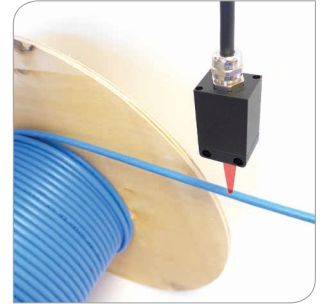

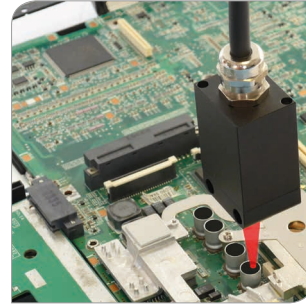

- High performance infrared temperature sensors
- Choice of specialised models for demanding applications
- Continuous LED sighting on all models shows position and size of measured spot while readings are being taken
- Current, voltage and alarm outputs
- Digital communications
- Optional touch-screen display with configuration and data logging



## PYROCUBE SENSOR SPECIFICATIONS

PyroCube Type	S			F		G			
Application	General purpose			Fast response		Glass			
Description									
Description	The general-purpose PyroCube S is suitable for measuring most non-reflective non-metals. Advantages over other general-purpose sensors are the built-in LED aiming light, fast response time, and small measured spot size.			The PyroCube F has a lightning-fast response time of 0.001 seconds.		Glass-specific measurement wavelength for improved accuracy when measuring glass surface temperature. G models are ideal for annealing, e.g. light bulb and fluorescent lamp manufacturing. GH models are suitable for high-temperature glass melting, such as in glass-to-metal sealing.			
Temperature Range	0°C - 500°C			50°C - 500°C Measurements below 50°C are possible with reduced stability		100°C - 1200°C Measurements below 100°C are possible with reduced stability		100°C - 2400°C Measurements below 100°C are possible with reduced stability	
Analogue output scale (adjustable via optional touch screen module or RS232)	Factory set: 4 mA = 0°C 20 mA = 500°C			Factory set: 4 mA = 0°C 20 mA = 500°C		Factory set: 4 mA = 50°C 20 mA = 1200°C		Factory set: 4 mA = 50°C 20 mA = 2400°C	
Response Time (adjustable up to 5 s via averaging function)	10 ms			1 ms		50 ms		10 ms	
Accuracy of Measurement †	± 3°C or 1%, whichever is greater			± 3.5°C or 1%, whichever is greater		All models: ± 3°C or 1%, whichever is greater -GH models: ± 2% above 1200°C			
Repeatability †	± 0.5°C			± 1°C		± 1°C		± 0.2% + 2°C	
Temperature Resolution †	<0.5°C			<0.7°C		0.5°C			
Spectral Response	2 - 7 µm					5 µm			
Model No. PCU-	S1.6	S1.6	S5.5	F3.5	F7.0	G7.0	G20.0	GH2.2	GH4.5
Focal Spot Diameter (mm)	1.6	3	5.5	3.5	7	7	20	2.2	4.5
Focal Distance (mm)	35	70	120	100	200	180	500	150	300
Maximum Measurement Distance (mm)	150	200	300	300	500	500	1000	300	500
Weight (without cable)	85g					85g		190g	

PyroCube Type	P	XS		M			
Application	Thin film plastics	Very small targets		Metals, low temperature			
Description							
	Accurately measures the temperature of thin film plastics that cannot be measured with general-purpose sensors. Materials include polyolefins, polyamide, polyethylene, polypropylene, polystyrene, nylon, PVC, acrylic, polyurethane and polycarbonate.	Extremely small measured spot size. Applications include measuring individual electronic component temperatures on a circuit board, and plastic welding where the seam is very narrow.		Short-wavelength sensors for measuring metals as cool as 50°C, with a very fast response time of 0.001 seconds and a very small measured spot size			
Temperature Range	120°C - 350°C Measurements below 120°C are possible with reduced stability	50°C - 500°C Measurements below 50°C are possible with reduced stability	100°C - 500°C Measurements below 100°C are possible with reduced stability	100°C - 600°C Measurements below 100°C are possible with reduced stability			
Analogue output scale (adjustable via optional touch screen module or RS232)	Factory set: 4 mA = 80°C 20 mA = 350°C	Factory set: 4 mA = 0°C 20 mA = 500°C		Factory set: 4 mA = 50°C 20 mA = 600°C			
Response Time (adjustable up to 5 s via averaging function)	10 ms	10 ms	50 ms	1 ms			
Accuracy of Measurement †	± 4°C	± 3°C or 1%, whichever is greater	± 5°C	± 3°C or 1%, whichever is greater			
Repeatability †	± 1°C	± 1°C	± 2°C	± (0.2% + 2°C)			
Temperature Resolution †	0.5°C	0.5°C	1.5°C	0.5°C			
Spectral Response	3.4 µm	5 - 7 µm		2.2 µm			
Model No. PCU-	P12.0	XSA0.7	XSB1.0	MA1.0	MA2.0	MA3.5	MB11.0
Focal Spot Diameter (mm)	12	0.7	1	1	2	3.5	11
Focal Distance (mm)	200	40	100	50	100	200	200
Maximum Measurement Distance (mm)	500	100	300	100	200	400	500
Weight (without cable)	85g	200g	85g	190g		85g	

## GENERAL SPECIFICATIONS (ALL MODELS)

Measurement Specifications	
<b>Emissivity Setting</b>	Adjustable, 0.3 to 1.0, via RS232C or optional touch screen interface
<b>Averaging</b>	Adjustable up to 5 seconds
<b>Target Sighting*</b>	Red LED built-in as standard on all models, shows the position and size of the measurement area. Switchable on/off.

### \* LED SIGHTING AND ALARMS

#### Sensor Only

These functions are selectable via RS232C and share a common connection, which is configurable either as an input to switch the LED sighting on/off, or an open drain alarm output, but not both at once.

#### Sensor with PM030

These functions may be configured via the PM030 interface. Two alarm relay outputs are provided in place of the open drain output.

Environmental Specifications	
<b>Environmental rating</b>	IP67
<b>Operating ambient temperature</b>	0°C to 50°C
<b>Storage temperature</b>	-15°C to 70°C
<b>Operating ambient humidity</b>	30% to 85% RH non condensing

Electrical Specifications	
<b>Outputs</b>	1 analogue output and 1 alarm output
<b>Analogue Output Type</b>	4-20 mA (set by default), 0-20 mA, mV/°C or voltage‡, selectable via optional PM030 touch screen interface
<b>Alarm Output*</b>	1 open drain alarm output, rated 27 V DC, 0.2 A
<b>Digital Communications</b>	RS232C Modbus RTU, non-isolated
<b>Output Cable Connection</b>	Hardwired
<b>Supply Voltage</b>	5 to 27 V DC, 100 mA max

Analogue Outputs (configurable via touch screen)	
<b>Output Type</b>	0 to 1 V DC mV/°C 0 to 20 mA 4 to 20 mA
<b>Effective Minimum Output</b>	30 mV 30 mV 0.2 mA 4.0 mA
<b>Output Accuracy (additional to Measurement Accuracy)</b>	±1.5 mV ±1.5 mV ±0.02 mA ±0.02 mA

† Ambient temperature 23 ± 5°C, emissivity 1.0, averaging time 50 ms  
‡ Voltage can be 0-1, 0-5, or 0-10 V DC, depending on model (see Model Numbers).

## PM030 - TOUCH SCREEN INTERFACE FOR PYROCUBE (ALL MODELS)



- Optional wall-mounted display, data logging, configuration and alarm unit for PyroCube sensor
- **Read the temperature**  
The large, bright backlit temperature display is visible from a distance and turns red in an alarm condition.
- **Record the temperature history**  
See a graph of the measured temperature, and log more than a year of data to a single MicroSD Card. The data is stored in a simple text format that can be imported easily into Excel.
- **Configure the sensor**  
All the sensor's configuration settings can be adjusted via the intuitive touch screen interface.
- **Trigger temperature alarms**  
Two alarms are individually configurable as high, low, band or error. The screen turns bright red to signal an alarm condition, and the built-in 24 V, 1 A relay outputs can be connected directly to alarm sounders and beacons.
- **Accurate measurements, even with reflections of hot objects**  
Place the sensor outside an oven or furnace and accurately measure the temperature of objects inside by using the Reflected Energy Compensation feature.

PM030 Specifications	
<b>Inputs</b>	1 x PyroCube sensor (any model)
<b>Outputs</b>	Retransmitted analogue output from PyroCube sensor, plus 2 relays, rated 24 V DC, 1 A
<b>Display Format</b>	2.83" (72 mm) resistive touch TFT, 320x240 pixels, backlit
<b>Touch Screen Display Format</b>	2.83" (72 mm) resistive touch TFT, 320 x 240 pixels, backlit
<b>Storage</b>	MicroSD Card (optional), max. 32 GB, equal to 16 years of data at the fastest sample rate of 1 per second
<b>Data Logging Interval</b>	1 second to 1 day (configurable)
<b>Internal Clock Battery</b>	1 x BR 1225 3V (not included)
<b>Variables Logged</b>	Instantaneous target temperature, hold temperature, alarm events
<b>File format</b>	.csv
<b>Configurable Parameters (Data Logging)</b>	Sample period Number of samples Scheduled start
<b>Configurable Parameters (Alarm Logging)</b>	Log times when triggered, acknowledged, reset Log data while triggered

Configurable Parameters
Languages English, Chinese (simplified), Japanese
Temperature units °C/°F
Displayed temperature
LED sighting on/off
Password
Date & time (for data logging time stamps)
Peak hold period, decay level
Averaging period
Correction (gain/offset)
Emissivity setting (with teach function)
Reflected energy compensation (with teach function)
Output type
Output temperature range
Polarity on error
Alarm mode, levels, hysteresis

### SCREENSHOTS (PM030 interface)

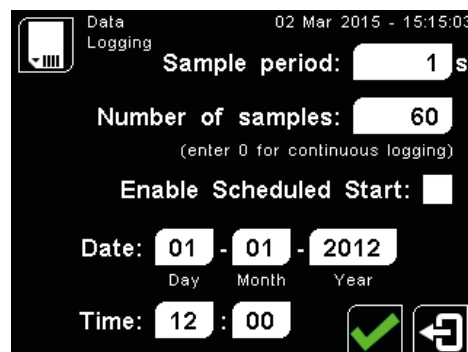
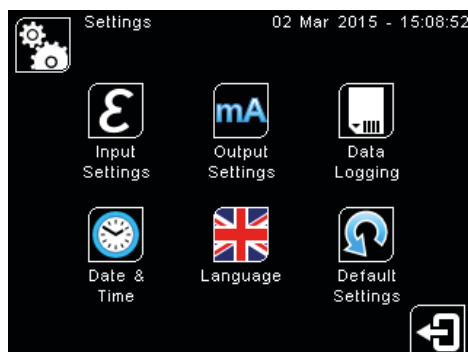
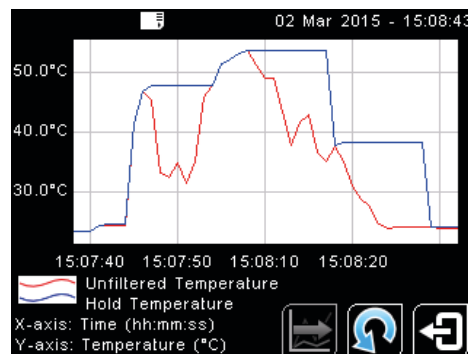
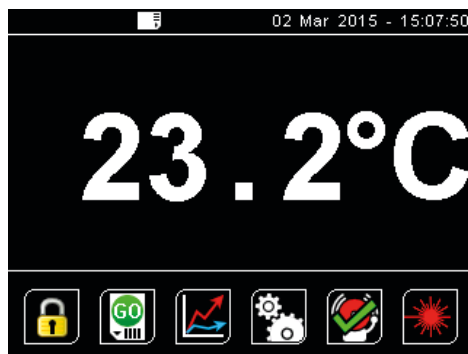

# OPTICS

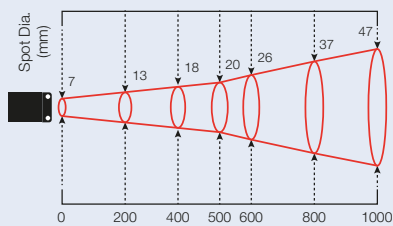

Distance: Sensor to object (mm)  
PCU-G20.0

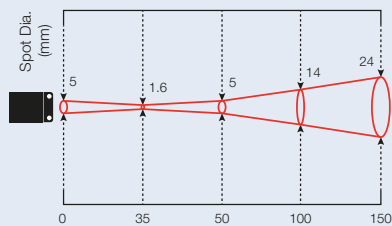

Distance: Sensor to object (mm)  
PCU-S1.6

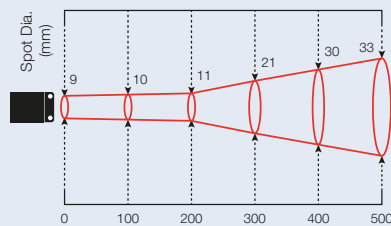

Distance: Sensor to object (mm)  
PCU-MB11.0

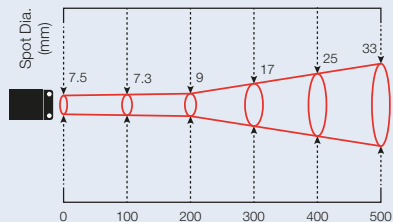

Distance: Sensor to object (mm)  
PCU-G7.0

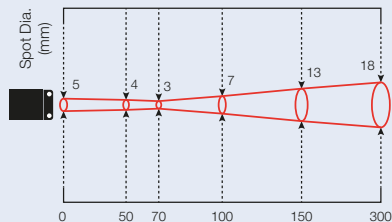

Distance: Sensor to object (mm)  
PCU-S3.0

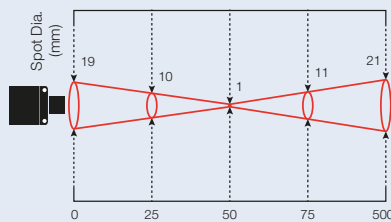

Distance: Sensor to object (mm)  
PCU-MA1.0

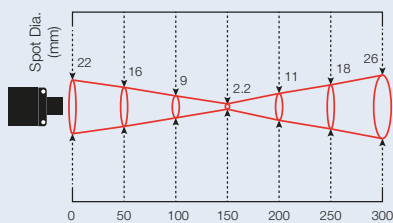

Distance: Sensor to object (mm)  
PCU-GH2.2

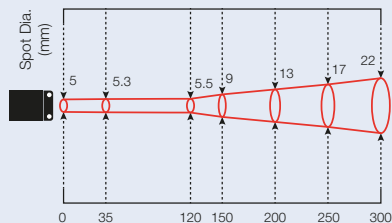

Distance: Sensor to object (mm)  
PCU-S5.5

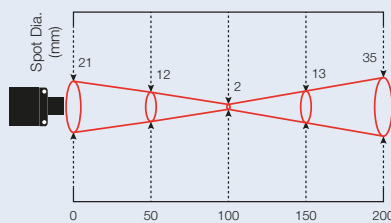

Distance: Sensor to object (mm)  
PCU-MA2.0

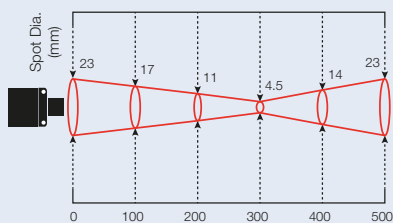

Distance: Sensor to object (mm)  
PCU-GH4.5

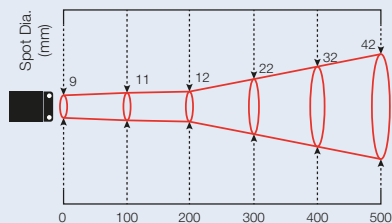

Distance: Sensor to object (mm)  
PCU-P12.0

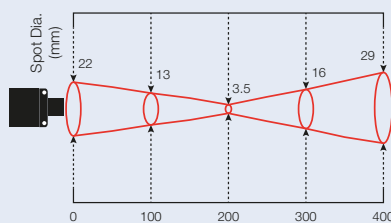

Distance: Sensor to object (mm)  
PCU-MA3.5

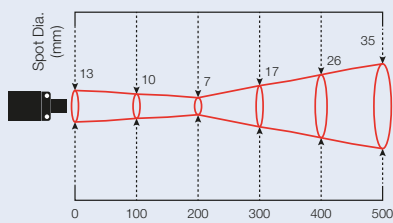

Distance: Sensor to object (mm)  
PCU-F7.0

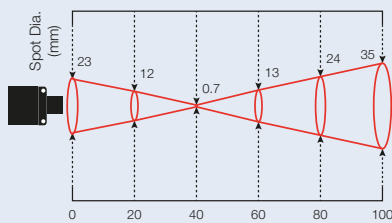

Distance: Sensor to object (mm)  
PCU-XSA0.7

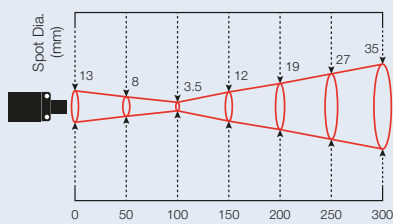

Distance: Sensor to object (mm)  
PCU-F3.5

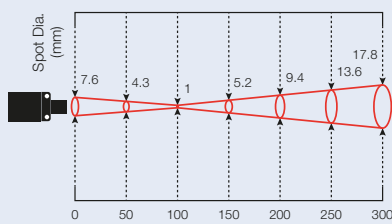

Distance: Sensor to object (mm)  
PCU-XSB1.0

PyroCube accuracy specifications are valid up to the maximum distances shown.

# DIMENSIONS

PyroCube Sensor  
S, F, G, P, XSB, MB models

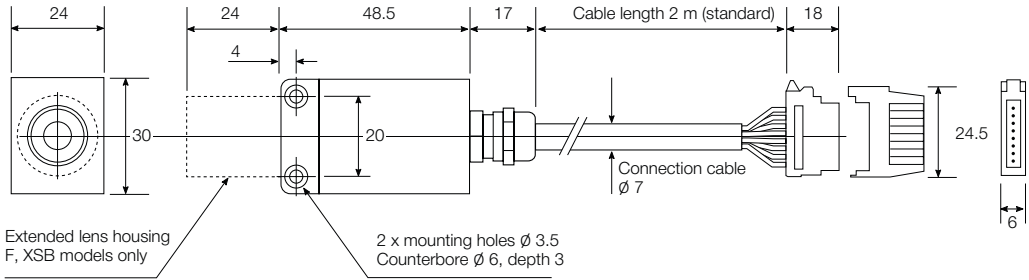

PyroCube GH, XSA, MA

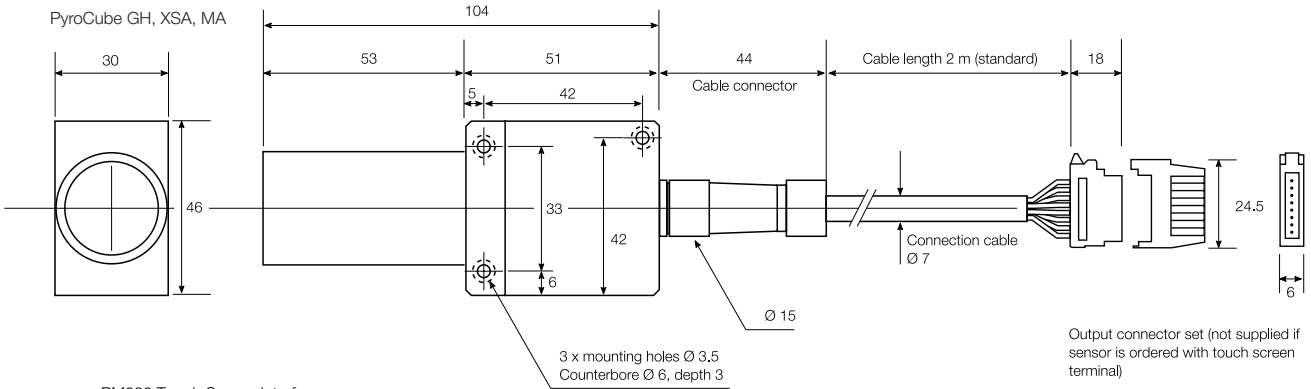

Output connector set (not supplied if sensor is ordered with touch screen terminal)

Easy-wire connectors for wire sizes  
28 to 20 AWG (0.08 to 0.5 mm<sup>2</sup>)  
Max sheath  $\varnothing$  1.5 mm

PM030 Touch Screen Interface

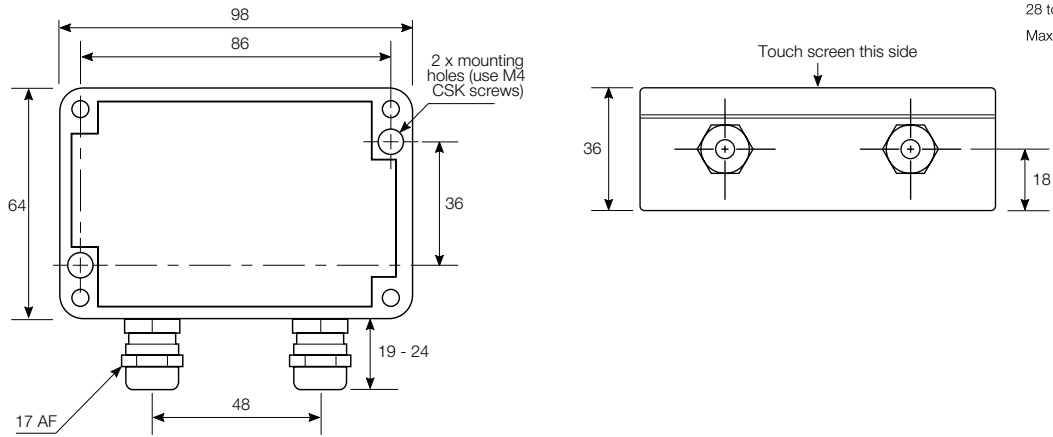

All dimensions in mm

# PYROCUBE CONNECTIONS - SENSOR ONLY

Analogue output	Minimum supply voltage
0 to 1 V	5 V
0 to 5 V	8 V
0 to 10 V	13 V
mV/°C	5 V
4 to 20 mA	2 V + (0.02 A x loop impedance [Ω])
0 to 20 mA	

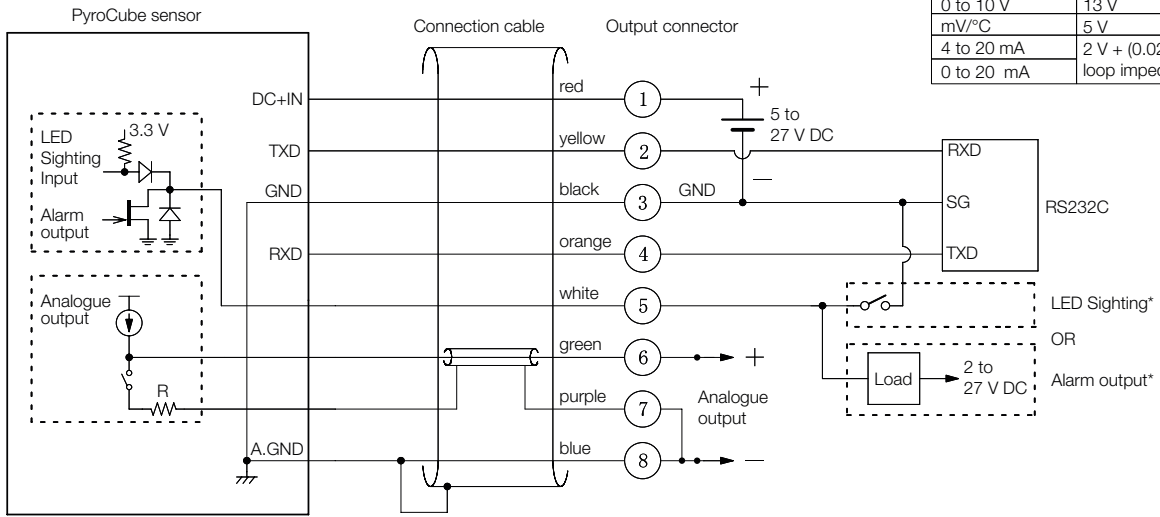

\* See LED SIGHTING AND ALARMS (with Specifications)

## PM030 CONNECTIONS

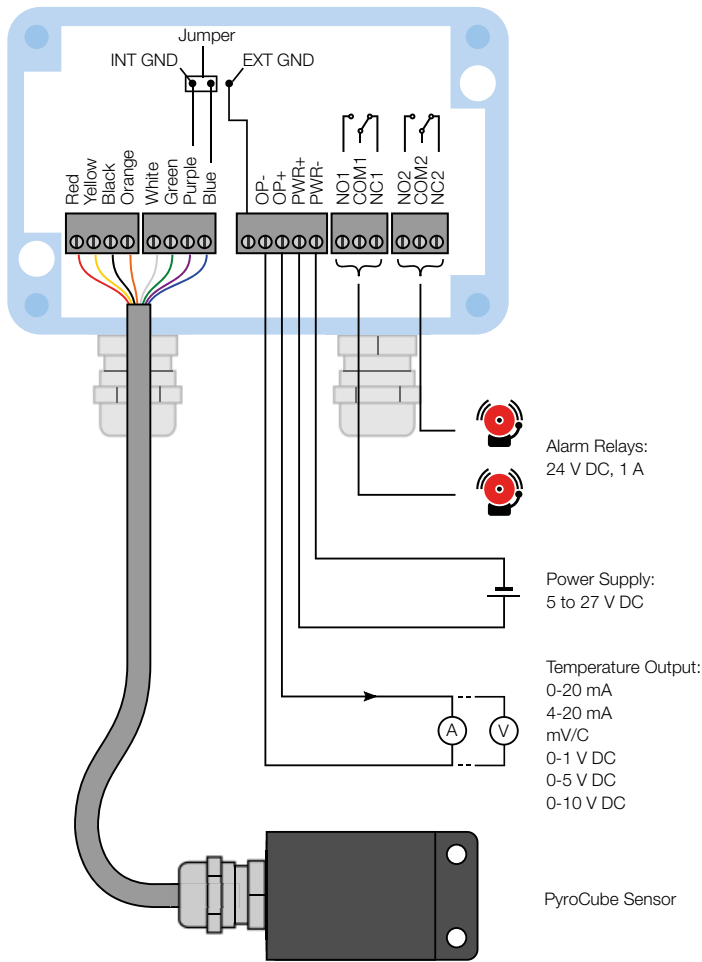

## ACCESSORIES

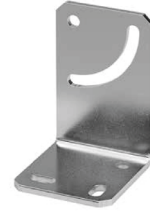

Mounting bracket



Protective lens cover



Air purge collar



Airless dust protector



Right angled mirror



Water Cooling Jacket



5 m extension cable with connectors



Panel Mounting Kit

## MODEL NUMBERS

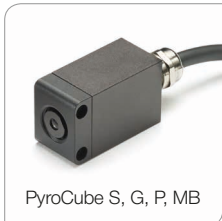

PyroCube S, G, P, MB



PyroCube F, XSB



PyroCube GH, XSA, MA



PCU - S1.6 - 2M - 1V

Series  
PCU = PyroCube  
sensor

PM030

Touch screen  
interface module  
for PyroCube  
sensor (any model)

### Voltage output option

1V = 0 to 1 V DC

5V = 0 to 5 V DC

10V = 0 to 10 V DC

Note: All models also have 0-20 mA, 4-20 mA, and mV/°C outputs as standard.

### Cable length

2M = 2 metres

5M = 5 metres

10M = 10 metres

### Response time and optics

S1.6 = 10 ms response, 1.6 mm spot at 35 mm distance

S3.0 = 10 ms response, 3.0 mm spot at 70 mm distance

S5.5 = 10 ms response, 5.5 mm spot at 120 mm distance

F3.5 = 1 ms response, 3.5 mm spot at 100 mm distance

F7.0 = 1 ms response, 7.0 mm spot at 200 mm distance

### Application and Optics

#### General Purpose

S1.6 = 1.6 mm measured spot diameter at 35 mm distance

S3.0 = 3 mm measured spot diameter at 70 mm distance

S5.5 = 5.5 mm measured spot diameter at 120 mm distance

#### Fast Response

F3.5 = 3.5 mm measured spot diameter at 100 mm distance

F7.0 = 7 mm measured spot diameter at 200 mm distance

#### Glass

G7.0 = 7 mm measured spot diameter at 180 mm distance

G20.0 = 20 mm measured spot diameter at 500 mm distance

GH2.2 = 2.2 mm measured spot diameter at 150 mm distance

GH4.5 = 4.5 mm measured spot diameter at 300 mm distance

#### Thin Film Plastics

P12.0 = 12 mm measured spot diameter at 200 mm distance

#### Very Small Measured Spot

XSA0.7 = 0.7 mm measured spot diameter at 40 mm distance

XSB1.0 = 1 mm measured spot diameter at 100 mm distance

#### Metals

MA1.0 = 1 mm measured spot diameter at 50 mm distance

MA2.0 = 2 mm measured spot diameter at 100 mm distance

MA3.5 = 3.5 mm measured spot diameter at 200 mm distance

MB11.0 = 11 mm measured spot diameter at 200 mm distance